

PLAN
GRID OMMITTED FOR CLARITY

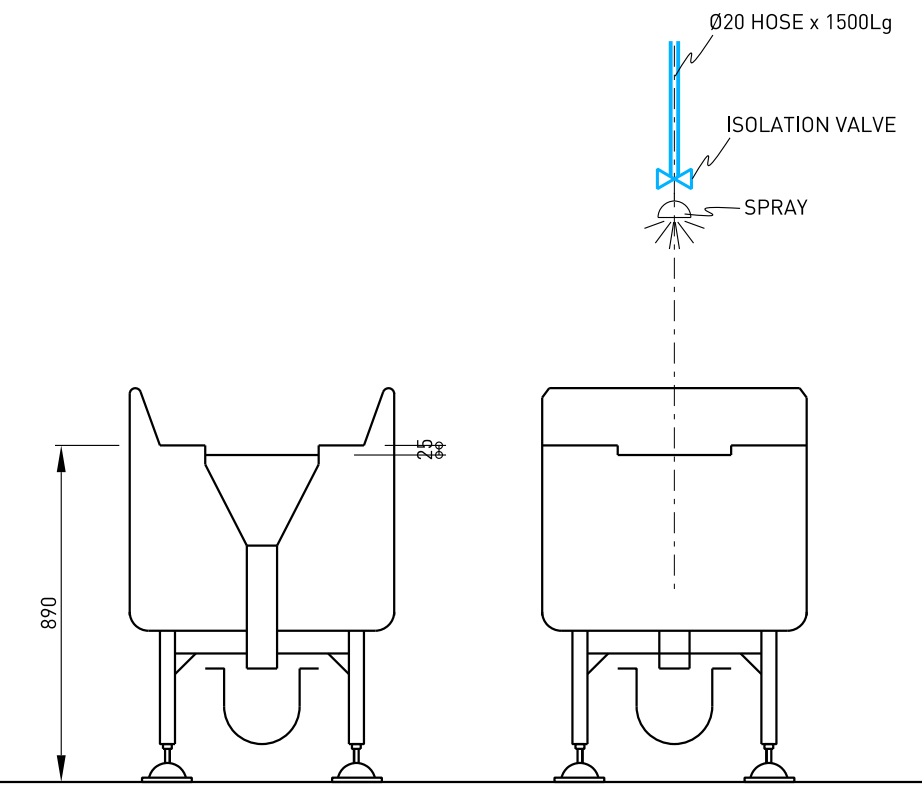

VIEW B-B

SECTION C-C

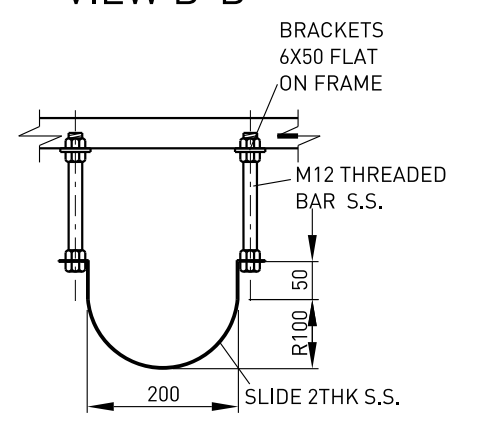

SECTION B-B
1:10

NOTES:

- TOP TO BE 304L STAINLESS STEEL 2mmTHK
- ALL WELDS TO BE CONTINUOUS
- SUPPORT FRAME TO BE MILDSTEEL HOT DIP GALVNISED AFTER FABRICATION.
- REMOVE ALL BURRS AND SHARP EDGES AND GRIND SMOOTH.
- HOLLOW SECTIONS TO BE CLOSED AND RENDERED WATERTIGHT.

SCIP ENGINEERING GROUP
JOHANNESBURG WITBANK
IN PARTNERSHIP WITH:
VAN VLIET DE WET & PARTNERS

PO Box 48550
Roosevelt Park, 2129
Johannesburg
Gauteng

Tel: 011 888 1425
Fax: 011 888 1075
joburg@scip.co.za
www.scip.co.za

PROJECT	ISIOLO COUNTY ABATTOIR		
DRAWING TITLE	CATTLE PAUNCH AND BIBLE WASH UNIT		

DRAWN:	G.M
DATE:	MARCH 2021

SCALE:	1:20
JOB NO.	1898

DETAIL NO.:	MD-31/B
REV.:	